

AQUALOOP Greywater Recycling System

AL-GW 300 l/day

✓ NSF 350 certified series



INTEWA GmbH

Auf der Hüls 182

52068 Aachen

Germany

+49 (0) 241 96605 0

info@intewa.de

www.intewa.com

Content

INTEWA AQUALOOP Greywater Recycling System - AL-GW300 l/d	3
Functional description.....	4
Main Components for Greywater Recycling	6
Water quality and safety	8
Dimensions and planning data	9
Lead time.....	9
Downloads and references.....	10
Additional INTEWA components for greywater recycling systems.....	11

INTEWA AQUALOOP Greywater Recycling System - AL-GW300 l/d

Your requirements – Our solutions

AQUALOOP greywater recycling systems as **packaged solutions** offer the following advantages:

- ✓ Pre-assembled greywater recycling system
- ✓ Low space requirement
- ✓ Experience: AQUALOOP systems are installed and work successfully in over 20 countries worldwide.
- ✓ Installation can be supported by online assistance of INTEWA experts.
- ✓ Saving water as valuable resource
- ✓ More independence from the drinking water supplier
- ✓ Pays for itself within a few years
- ✓ INTEWA is **the only company worldwide with NSF 350:2014 Class C certification** for their series of commercial grey water recycling systems, guaranteeing excellent treated water quality and safety.
- ✓ AQUALOOP is certified according to British Standard BS 8525-2:2011 for the most critical application. BS certified systems must be additionally equipped with a UV unit.



Functional description

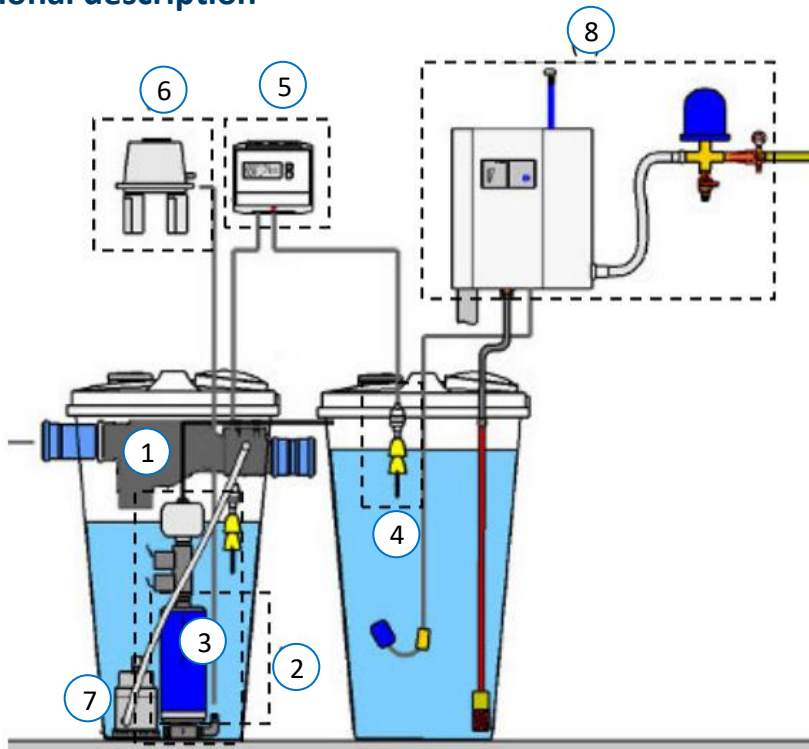

Figure 1: Overview: Packaged system AQUALOOP Greywater Recycling System 300 l/day
Note: metal rack, drainage pipes, aerator hoses on site

1. PURAIN filter
2. Bioreactor
3. AQUALOOP Membrane station (incl. filtration & backwash pump)
4. Clear water tank
5. AQUALOOP control system
6. Blower for membrane station
7. Sludge pump

Prefiltration and bioreactor

In the AQUALOOP complete greywater systems, we use prefabricated, stable, opaque and reinforced internal tanks.

The greywater from showers, bathtubs and hand washbasins is pre-filtered through a highly efficient PURAIN filter (1) before entering the bioreactor (2). The dirt collected in the PURAIN filter is regularly flushed back into the sewer using a backwash nozzle.

In the core of the plant, the bioreactor, a continuous biological degradation takes place. The required oxygen is supplied by a blower (6) which is a prerequisite for the growth of the bacteria in the grey water. Here the bacteria settle on the AQUALOOP growth bodies, which are special suspended beds with a large surface area. A sludge pump (7), which is also located at the bottom, periodically removes the resulting sediments.

Membrane station and control

The bioreactor also contains the AQUALOOP membrane station (3), which filter the greywater into the clear water storage tank (4). For this purpose, the membrane station is equipped with a filtration and backwash pump. Due to the small membrane pore size of 0.02 µm, particles, bacteria and viruses are retained by ultrafiltration.

The membranes are periodically cleaned by backwashing and by coarse air bubbles. The 300 l/d system is controlled here with the aid of an AQUALOOP controller (5).

Further process

The clean service water is pumped to the consumers by our various pressure boosting systems, such as the RAINMASTER Eco (8) systems, depending on the calculated and required flow rate and pressure. The service water can be used for consumers such as toilets, washing machines or irrigation. In order to achieve the greatest possible safety, the already ultrafiltrated service water passes through a UV treatment as the last stage. The dimensioning of the UV disinfection system is done according to the dimensioning of the pressure boosting system.



Main Components for Greywater Recycling



1. PURAIN filter

The PURAIN DN100 high-efficiency, self-cleaning filter with integrated skimmer overflow is installed inside of the bioreactor tank. It is equipped with a backflush nozzle for an automatic cleaning.



2./4. Bioreactor and clear water tank

The 350 l tanks are used as well for bioreactor and clear water tank. They are pre-installed as much as possible. Different tank sizes results in the best suitable tank configuration for each greywater system.



3. AQUALOOP membrane station

This station comprises a platform for mounting the membrane. A filtration pump, backwash pump, backwash tank and blower connection are all integrated. The system 300 l/day includes one station with single membrane. The specialized hollow membrane fibers with a pore size of 0.02 μm reliably prevent passage of bacteria and viruses. Each membrane cartridge has a filtration area of 6 m^2 . The innovative construction and design allow for long-lasting operation up to 10 years with only minimal maintenance effort.

Main benefits of AQUALOOP membranes to other Membrane Filtration Systems

- ✓ AQUALOOP membrane fibres protected in cartridges
- ✓ Cartridges allow higher fluxes and protect the fibres from frequent clogging through with air scouring.
- ✓ AQUALOOP fibres and cartridges allow more equal distribution of applied pressures and flows because they are within a small range of hydrostatic pressure difference (only about 40 mbar compared to up to 200 mbar pressure difference in other systems).
- ✓ The handling of AQUALOOP cartridges is user friendly and can be lifted much easier than conventional plate or hollow fibre systems.
- ✓ AQUALOOP CIP allows cleaning chemicals to work directly on the membrane without any dilution or chemical contamination of the surrounding bioreactor media.



5. AQUALOOP control system

This fully automatically controls the AQUALOOP water treatment plant. The operating status can be easily read from an illuminated LCD display. The controller has several advantages.



6. AQUALOOP blower for membrane station

With AQUALOOP technology, air is supplied through the blower which performs several functions at the same time:

- Cleaning of the membrane fibers by creating turbulence through the fibers
- Cleaning the fluidized-bed growth bodies
- Introduction of oxygen



7. Sludge pump

This pump serves to automatically remove sludge from the bioreactor.



AQUALOOP growth bodies

Special floats with a large surface area, on which the bacteria settle and enable biological cleaning.

Water quality and safety

INTEWA greywater systems deliver crystal-clear water through ultrafiltration.

The INTEWA test system was able to meet all requirements and was thus the first and so far only system to be certified according to "Class C". In contrast to Class R (turbidity 5 NTU, E.coli 14 MPN/100 ml as average values), Class C, for example, may reach a maximum of 2 NTU and 2.2 MPN/100 ml E.coli on average. Class C systems are intended in particular for commercial greywater systems. Overall, the entire INTEWA system series AL-GW300 to AL-GW5400 could be certified according to NSF/ANSI 350-2014.

For larger systems, INTEWA is authorised to issue an NSF declaration of conformity, which entitles the holder to carry the NSF certificate. For this purpose, INTEWA will perform a system-specific verification of compliance with the specifications of the INTEWA NSF report. See the confirmation of the official NSF listing.

	Influent range source water ⁴	Requirement effluent NSF/ANSI 350-2014 Class C		AQUALOOP effluent Test results NSF approval Class C	
		Test Average	Single Sample Maximum	Result Average	Single Sample Maximum
BOD₅ [mg/l]	130 – 180	--	--	--	--
CBOD₅ [mg/l]	--	10	25	5	17
TSS [mg/l]	80-100	10	30	2	7,8
turbidity [NTU]	50-100	2	5	0,57	3,89
E. coli ²	10 ² -10 ⁴ cfu/100ml	2,2 MPN/100ml	200 MPN/100ml	1,0 MPN/100ml	13,0 MPN/100ml
pH	6,5 – 8,0	6,0 – 9,0	NA ¹	7,38	NA ¹
color	--	MR ³	NA	MR ³	NA
odor	--	Non offensive	NA	Non offensive	NA
oily film and foam	--	Non-detectable	Non-detectable	Non-detectable	Non-detectable

1 NA: not applicable

2 calculated as geometric mean.

3 MR: measured and reported only.

4 System for treating bathing and laundry source waters (combined)

Dimensions and planning data

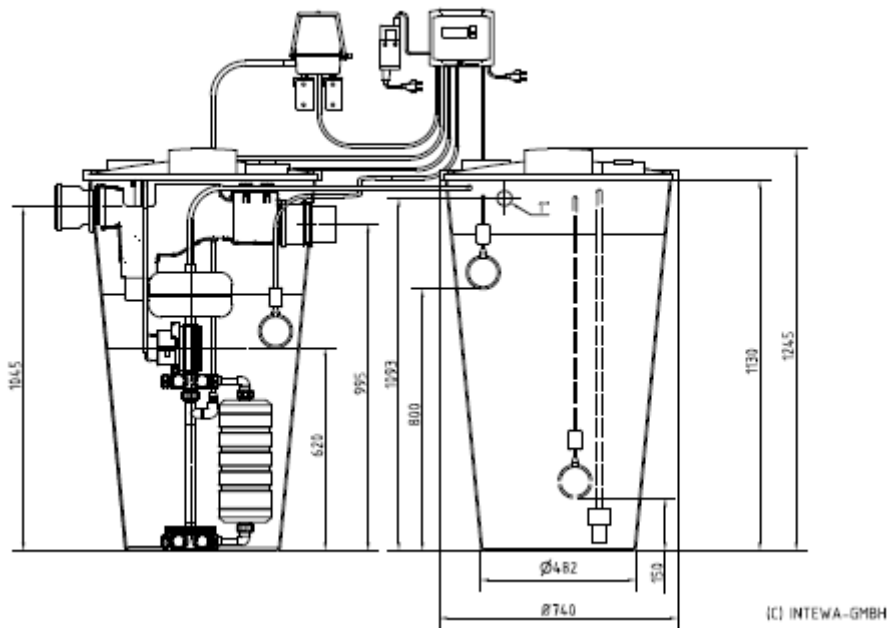

Figure 2: Dimensions and connections AQUALOOP AL-GW300 l/d

Technical Data:

Treatment capacity:	300 l/day
Length:	1790 mm
Width:	750 mm
Inlet connection:	DN100 (Ø110mm)
Emergency overflow:	DN100 (Ø110mm)
Floor space required:	approx. 1.2 m ²
Ceiling height required:	1900 mm
Net weight, without water:	23 kg
Weight max. (filled with water):	773 kg
Drainage connection:	DN100 (Ø110mm) and floor drain
Voltage:	110-230 VAC/50 Hz
Power input, max.:	0.3 kW
Power requirement/ m ³ :	5.8 kWh/m ³

Shipping packaging:

2 x pallets (120 x 80 x 140 cm)	1.4 m ³ / 100 kg
---------------------------------	-----------------------------

Lead time

INTEWA GmbH specifies a **lead time of minimum 2 weeks** from deposit being paid to system component delivery to site.

Shipping details or pickup agreements have to be defined separately.

Downloads and references

System Overview

Greywater for Single family house <https://www.intewa.com/en/water-treatment/domestic/greywater-recycling/>

Pre-assembled systems <https://www.intewa.com/en/water-treatment/commercial/greywater-recycling/pre-assembled-systems/>

More details

AQUALOOP <https://www.intewa.com/en/products/aqualoop/membranes/>

Greywater recycling complete system <https://building.intewa.net/en/360-exhibition/greywater-recycling-complete-system>

References



Single family house in Kelmis / Belgium / 2017
<https://www.intewa.com/en/references/simple-inexpensive-the-best-home-water-source/>



ECOBUILT Homes in Christchurch / New Zealand / 2014
<https://www.intewa.com/en/references/ecologically-built-house-in-christchurch/>







Residential house in Gauteng / South Africa / 2016
<https://www.intewa.com/en/references/greywater-use-in-south-africa/>

Additional INTEWA components for greywater recycling systems

The clean service water is pumped to the consumers by our various pressure boosting systems. INTEWA can offer these systems depending on the calculated and required flow rate and pressure. All technical data of the below mentioned products can be seen in our store

<https://www.intewa-store.com/start.aspx>

INTEWA sales team helps to find the best suitable solution.

	<p>MULTI Submersible pumps type</p> <p>https://www.intewa.com/en/intewa-products/pumps/ -additional mains water top up included</p>
	<p>RAINMASTER Eco</p> <p>With 75% energy savings compared to conventional domestic waterworks, the RAINMASTER Eco is suitable for particularly energy-conscious users. In a single-family home, the volume flow of 10 l/min is usually sufficient for low garden watering requirements</p> <p>https://www.intewa.com/en/products/rainmaster/</p>
	<p>RAINMASTER Favorit</p> <p>The RAINMASTER with different power levels and integrated mains water top up draws the treated water from the clear water tank to the consumers.</p> <p>https://www.intewa.com/en/products/rainmaster/</p>
	<p>UV Unit</p> <p>The UV units are installed behind the pressurizing system to the reuse consumers (toilets, washing machine, irrigation, cleaning, and so on). The UV units deliver an additional second safety in case of a bacteria growth in the clear water storage tank with the disinfected membrane filtered water.</p> <p><u>According to BS, UV unit is a mandatory part of the greywater system.</u></p> <p>https://www.intewa.com/en/intewa-products/uv-unit/</p>

NSF Certification confirmation for AQUALOOP

The INTEWA system is the first and only system in the world to be certified to the high NSF Standard Class C (commercial type) standard for commercial installations and also to the British Standard for spray irrigation.



OFFICIAL LISTING

NSF certifies that the products appearing on this Listing conform to the requirements of NSF/ANSI 350 - Onsite Residential and Commercial Water Reuse Treatment Systems

This is the Official Listing recorded on February 11, 2019.

INTEWA Ingenieur-Gesellschaft für Energie- und Wassertechnik GmbH
Auf der Hüls 182
Aachen 52068
Germany
49 241 966 050

Facility: Aachen, Germany

Model Number	Rated Capacity Gallons/Day	Classification	Type
AQUALOOP System GW300	79	Class C	Laundry & Bathing
AQUALOOP System GW600	158	Class C	Laundry & Bathing
AQUALOOP System GW900	238	Class C	Laundry & Bathing
AQUALOOP System GW1200	317	Class C	Laundry & Bathing
AQUALOOP System GW1500	396	Class C	Laundry & Bathing
AQUALOOP System GW1800	476	Class C	Laundry & Bathing
AQUALOOP System GW3600	951	Class C	Laundry & Bathing
AQUALOOP System GW5400 ^[1]	1427	Class C	Laundry & Bathing

[1] Larger systems available in accordance with treatment volume and duration specified in the INTEWA NSF Final Report and Certification.

Note: Additions shall not be made to this document without prior evaluation and acceptance by NSF.

1 of 1

789 N. Dixboro Road, Ann Arbor, Michigan 48105-9723 USA
1-800-NSF-MARK / 734-769-8010
www.nsf.org

C0241944